



5" Coaxial Speaker, 70/25 Volt transformer, High Style Grille with Back Box, UL listed.

FEATURES

Ideal for audio and video conferencing, also used in Restaurants, Boardrooms, Class Rooms, Conference Rooms, Retail Stores, Malls, Airports, Train Stations, Warehouse and anywhere a commercial background or foreground Music or Paging is required. Designed for quick and easy Mounting makes it ideal for all ceiling type installations in new and existing constructions. Speaker system comes completely assembled.

APPLICATIONS

The QCS-2052T is an aggressively priced, high quality speaker/transformer/ back box package suitable for most any paging or background application including retail stores, restaurants, schools and other institutional facilities. Ships in pars and comes with c-ring and mounting channels.

Specification Technique	QCS-CM2052T
Core Speakers / Moteurs:	5" coax. (205mm)
Sensitivity / Sensibilité:	88dB SPL 1W/1M (average)
Max SPL:	98db RMS, 104dB Peek
Rated Power / Puissance:	40W Nominal (8 ohms), 80 W cont.
Frequency response / Bande passante:	70 HZ - 22 kHz (nominal)
Tapping 70V / Puissance en ligne:	10W, 5W, 2.5W, 1.25W, 0.625W
Impedance Tapping / Impédance :	500, 1000, 2000, 4000, 8000 and 8 (ohms).
Dispersion Angle / Directivité (-6 dbA):	130 deg Hor. X 130 deg vertical
Back Can:	metal
Cone:	Wool Paper Cone
VC Diameter:	1" (25mm)
Tweeter:	¾" (19 mm) silk dome
Transformer / Transformateurs:	10 watt max, 5 taps (self leads). Insertion loss, less than 1db. / (Perte par insertion moins que 1db)
Magnet Weight:	Nominal, 10oz. (260g) STRONTIUM MAGNET
Grill / Grille:	Aluminium
Dimensions	8.125" (205mm) Dia. & 2.875" (73mm) Deep
Mounting / Montage	7.625" (194mm) Bolt Circle
Net weight / Masse:	2.45 Kgs, (5.4 Lbs)
Shipping Weight:	6.5Kgs (14.3lb)
Finish/ Couleur:	White / Blanc
Reference / Référence	QCS-CM2052T

Ce document n'est pas contractuel; toute modification pouvant intervenir sans préavis / This document is not legally binding, we reserve the right to modify descriptions and specifications without notice.

QCS-CM2052T

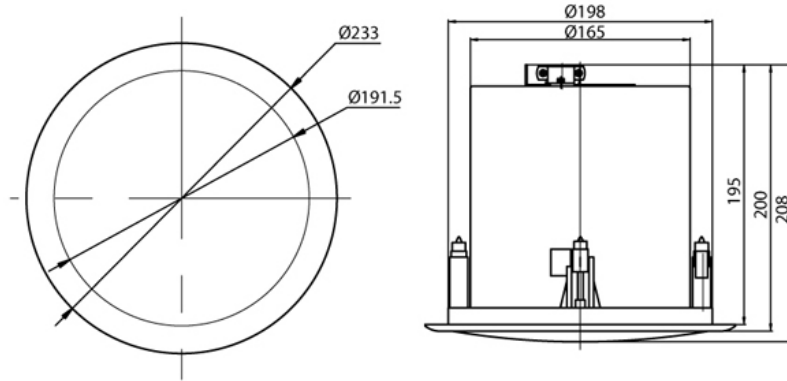

Included accessories :



Installation Instructions

Precautions for on-site installation:

- Installation must be completed by a qualified technician.
- All speakers must be connected in parallel to each other and terminated to the required line terminal of a 70.7 v constant voltage amplifier.
- Total speaker impedance or wattage must not exceed the amplifier rating.
- Set the impedance / watt tap of the speaker to the required operational mode.
- To ensure optimum results all speakers must be connected in phase with each other, (same polarity).
- Do not change impedance watt tapping while speaker is in use.

Instructions d'installation

Précautions d'installation en chantier:

- L'Installation doit être faite et complétée par un technicien qualifié.
- Tous les haut-parleurs doivent être reliés en parallèle et doivent être terminés aux bornes à vis appropriées d'un amplificateur à voltage constant 70.7 volts
- L'impédance et le wattage total des haut-parleurs ne doivent pas excéder la capacité de l'amplificateur.
- Régler le sélecteur d'impédance et de wattage de chaque haut-parleur à la position requise.
- Pour un résultat optimum, toujours brancher tous les haut-parleurs en phase, c'est-à-dire avec la même polarité.
- Ne pas changer la position du sélecteur d'impédance /watts lorsque le haut-parleur est en tension.

Wiring Diagram / branchements

TAP WATTAGE 70.7V		
0.625 W	8000 ohms	
1.25 W	4000 ohms	
2.5 W	2000 ohms	Red
5 W	1000 ohms	
10 W	500 ohms	
COMMON	-	Black